

----- CHASSIS -----
 CHASSIS: KME PREDATOR XLFD W/22" RR ALUM
 CAB: 4 DOOR
 ENGINE: DETROIT SERIES 60 515 HP
 TRANSMISSION: ALLISON 4000 EWS 5 SPD
 FRONT AXLE: 22,500#
 REAR AXLE: 48,000#

----- PUMP -----

PUMP: HALE QMAX-150 1500 GPM SINGLE STAGE
 INTAKES
 DRIVER SIDE: 6" & 2 1/2"
 OFFICER SIDE: 6"
 FRONT: 6"
 REAR: 6"
 DISCHARGES:
 DRIVER SIDE: (3) 2 1/2" & (1) 4"
 OFFICER SIDE: (1) 2 1/2" & (1) 1 1/2"
 FRONT: (1) 1 1/2" & (1) 2 1/2"
 REAR: (1) 2 1/2" DS
 DECK GUN:
 (1) 3" 3/4" SPEEDLAYS
 OTHER: (2) 1 3/4" SPEEDLAYS
 (1) 2 1/2" SPEEDLAYS

----- TANK -----

TANK: POLY
 WATER: 2,500
 FOAM: 50/50
 EXTRA FILLS: (1) 2 1/2" FIREMANS FRIEND DS REAR
 DUMPS: REAR NEWTON

----- BODY -----

BODY TYPE: 213 FLATBACK
 MATERIAL: 12 GA STAINLESS STEEL
 COMPARTMENTATION
 DRIVER SIDE: FULL HEIGHT-SPLIT DEPTH
 OFFICER SIDE: FULL HEIGHT-SPLIT DEPTH
 HOSEBED
 CAPACITY: 10" DEEP
 DIVIDERS: TWO (2)
 HOSE LOAD:

----- MISC. -----

GENERATOR: ONAN 15,000 WATT MOBILE PTO/HYD
 FOAM SYSTEM: HALE CAFS PRO 1000 GPM/200CFM

CUSTOMER APPROVAL:

NAME: _____
 TITLE: _____
 DATE: _____

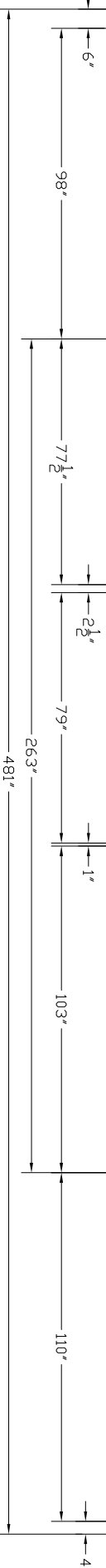
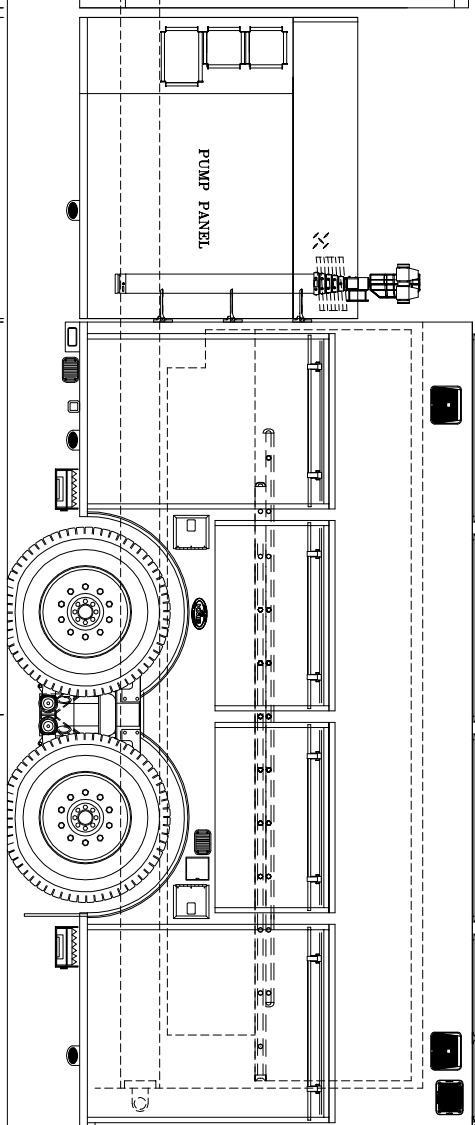
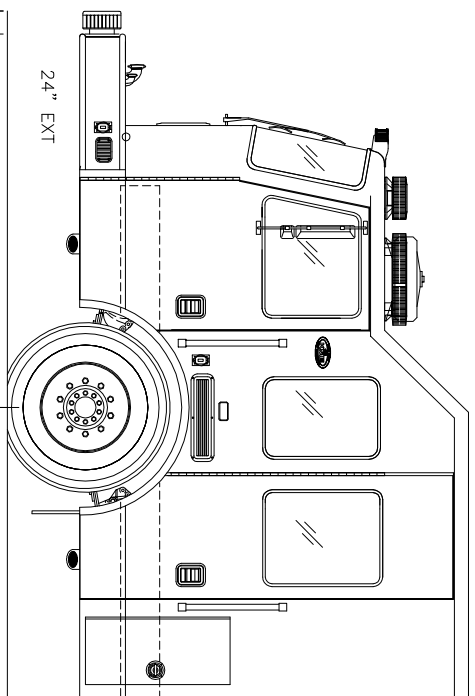
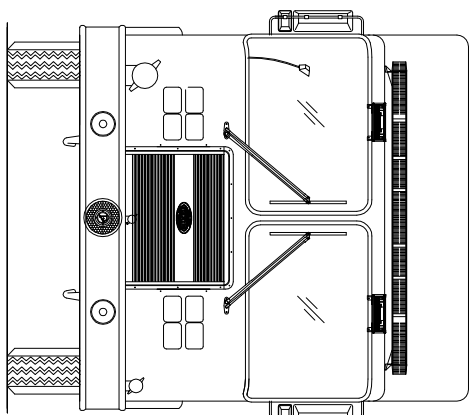
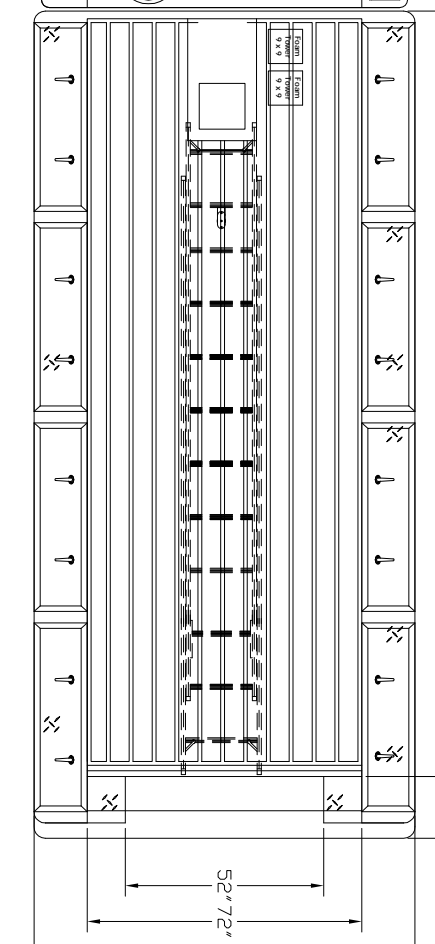
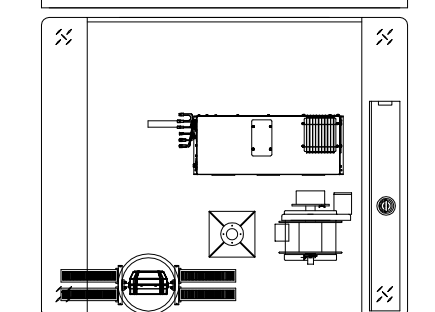
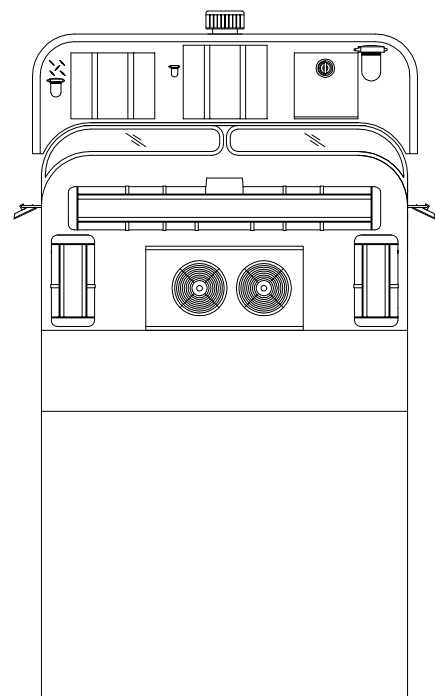
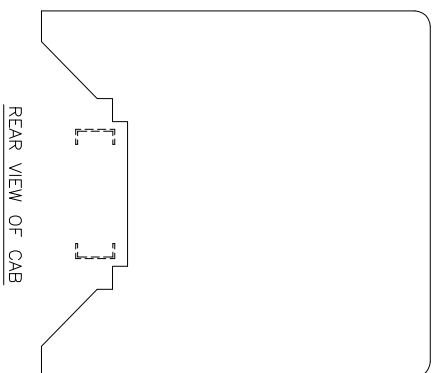

THIS DRAWING IS A GENERAL CONFIGURATION AND MAY NOT NECESSARILY REFLECT ALL CONTRACTUAL REQUIREMENTS. CONTRACT SPECIFICATIONS SHALL PREVAIL OVER DRAWING.

SY#	DATE	REVISION DESCRIPTION	APP'D
B	6-2-09	REVISED PROPOSAL	RM
A		PROPOSAL	DK
SY#	DATE	REVISION DESCRIPTION	APP'D

SALES ENGINEER :



KOVATCH MOBILE EQUIPMENT
 ONE INDUSTRIAL COMPLEX - NESQUEHONING, PA 18240

DATE: 12-12-07
 SCALE: 1"=24"
 DWG SIZE: D
 DRAWN BY: JIM
 APPROVED BY: JIM

KME CUSTOM PUMPER

ALLEN VFC INC, MD

PROPOSAL