

SPECIFICATIONS

CHASSIS: KME PANTHER MPD W/10" RAISED ROOF
 ENGINE: CUMMINS ISL 400 H.P. W/JAKE
 TRANSMISSION: ALLISON 3000EVS 5-SPD AUTO
 FRONT AXLE: 16,540#
 REAR AXLE: 24,000#
 RESCUE BODY: 14'-6" WA ALUMINUM

COMPARTMENT SIZE

(A/E): 66"H x 49 1/4"W x 29"D
 (B/F): 66"H x 23 1/8"W x 29"D
 (C/G): 35 3/4"H x 57 1/2"W x 29"D
 (D/H): 66"H x 49 1/4"W x 29"D

DOOR OPENING

(A/E): 67"H LESS LIFT BAR HEIGHT x 46"W
 (B/F): 67"H LESS LIFT BAR HEIGHT x 21"W
 (C/G): 31 9/16"H LESS LIFT BAR HEIGHT x 53"W
 (D/H): 67"H LESS LIFT BAR HEIGHT x 46"W

**PLEASE REVIEW AND RETURN
 A SIGNED COPY.**

NAME: _____

TITLE: _____

DATE: _____

CUSTOMER PAINT CODES:

LOWER CAB AND BODY: _____

CAB TWO TONE: _____

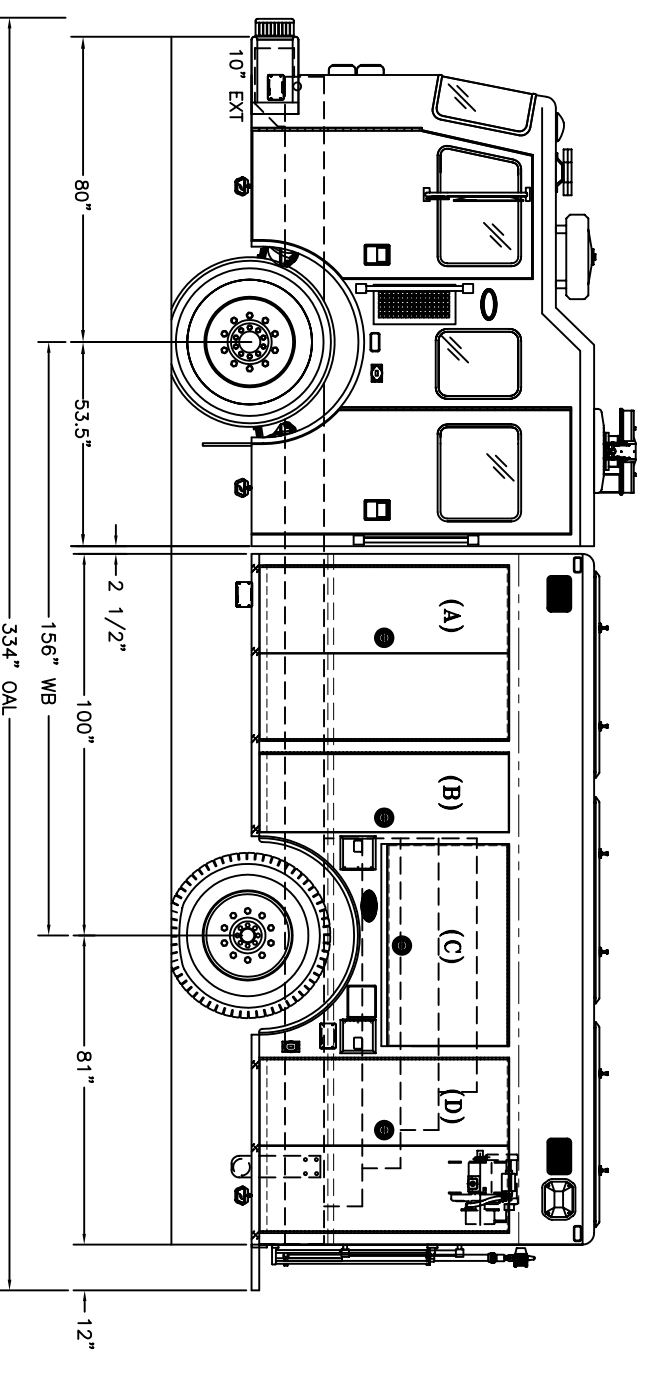
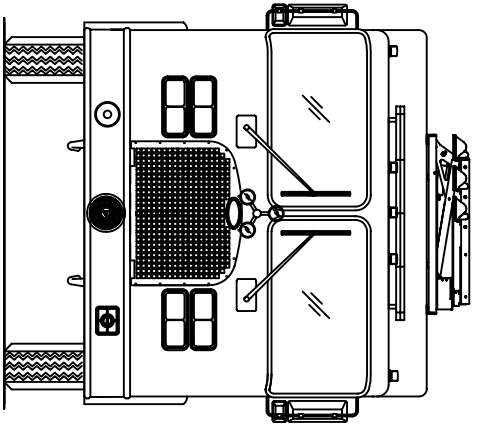
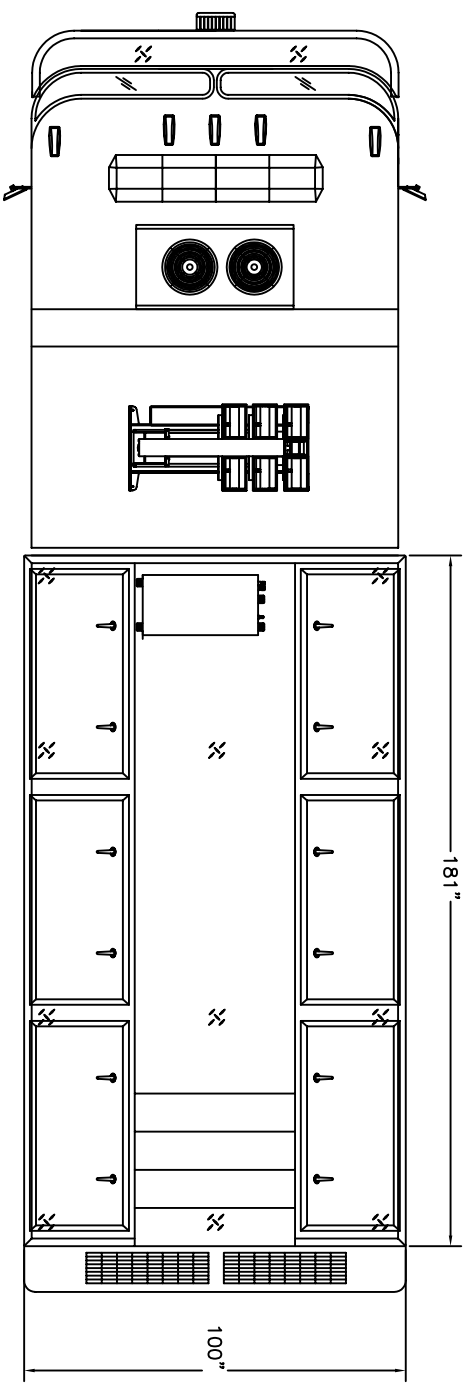
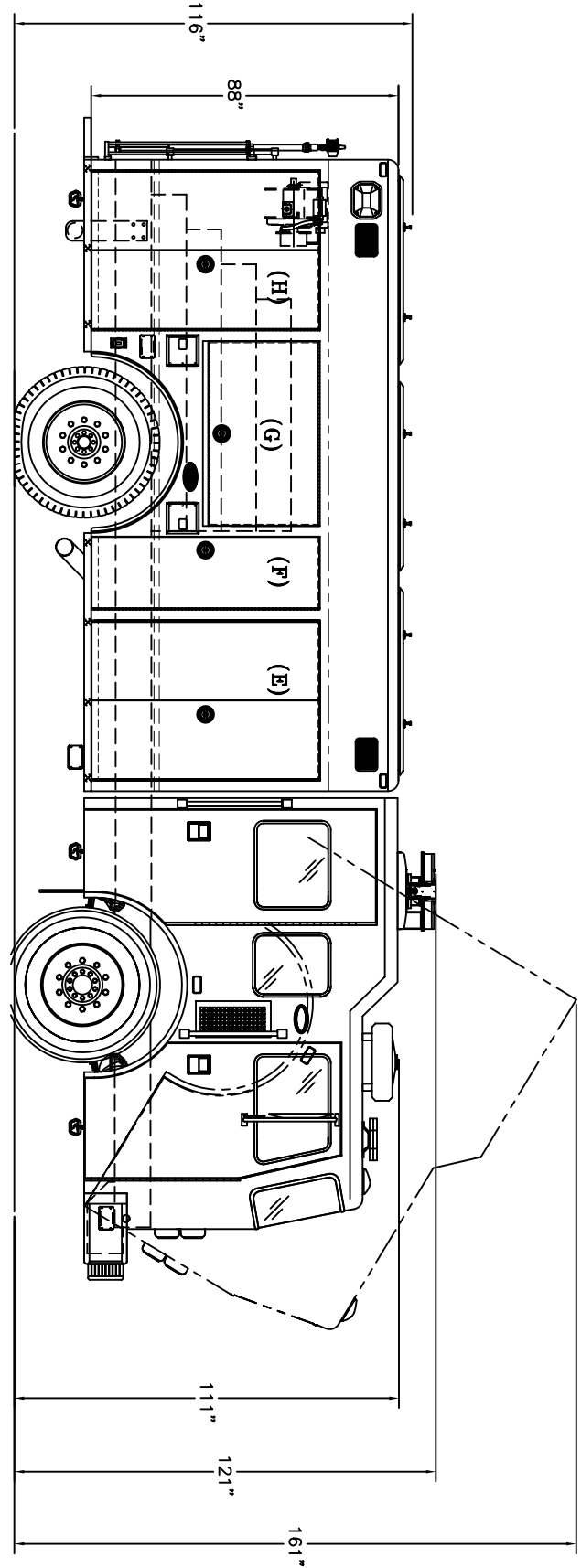
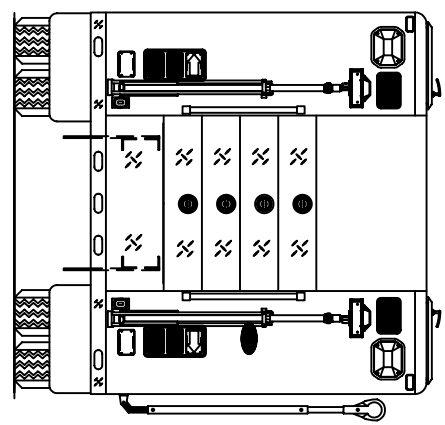

| SYM | DATE | REVISION DESCRIPTION | APP'D |
|-----|------|----------------------|-------|
| A | | PROPOSAL | |

KOVATCH MOBILE EQUIPMENT
 ONE INDUSTRIAL COMPLEX
 NESQUEHANNING, PA 18240

TOLERANCE UNLESS OTHERWISE SPECIFIED
 DECIMALS ± .060 THREE PLACE ± .010 FRACTIONS ± 1/8"
 ONE PLACE ± .030 ANGLES ± 2° HONED ALL EDGES
 TWO PLACE ± .030 AND SHARP EDGES

DATE: 6-29-05 SCALE: NONE DRAWN BY: JIM APPROVED BY: _____

CAD

**KME CUSTOM HEAVY RESCUE
 KEYSER VFD, WV**

PROPOSAL